

SECTION **EX**
EXHAUST SYSTEM

A
EX
C
D
E
F
G
H
I
J
K
L
M
N
O
P

CONTENTS

VQ35HR	Commercial Service Tool	3
PRECAUTION	PERIODIC MAINTENANCE	4
PRECAUTIONS	EXHAUST SYSTEM	4
Precautions Concerning On-board Servicing of Hybrid Systems	Inspection	4
Removal and Installation	REMOVAL AND INSTALLATION	5
PREPARATION	EXHAUST SYSTEM	5
PREPARATION	Exploded View	5
Special Service Tool	Removal and Installation	6
	Inspection	6

PRECAUTION

PRECAUTIONS

Precautions Concerning On-board Servicing of Hybrid Systems

INFOID:000000008141355

CAUTION:

Be sure to turn the ignition switch OFF before performing inspection and servicing inside the engine compartment or underneath the vehicle. If the ignition switch is ON (vehicle READY state), even if the engine is stopped, the conditions of the vehicle may cause the engine to start automatically.

If it is necessary to continually operate the engine during inspection or servicing, use the designated inspection mode. [HBC-89. "Description"](#).

Removal and Installation

INFOID:000000008141356

CAUTION:

- Be sure to use genuine exhaust system parts or equivalents which are specially designed for heat resistance, corrosion resistance, and shape.
- Perform the operation with the exhaust system fully cooled down because the system will be hot just after engine stops.
- Never cut your hand on the heat insulator edge.

PREPARATION

< PREPARATION >

[VQ35HR]

PREPARATION

PREPARATION

Special Service Tool

INFOID:000000008141357

A

EX

The actual shapes of Kent-Moore tools may differ from those of special service tools illustrated here.

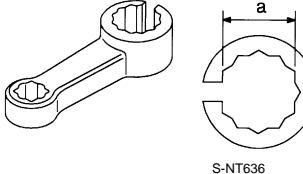
Tool number (Kent-Moore No.) Tool name	Description
KV10114400 (J-38365) Heated oxygen sensor wrench 	Loosening or tightening heated oxygen sensor 2 For 22 mm (0.87 in) (a) width hexagon nut

C

D

E

Commercial Service Tool

INFOID:000000008141358

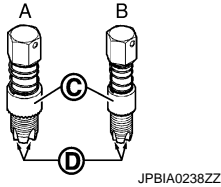
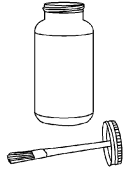
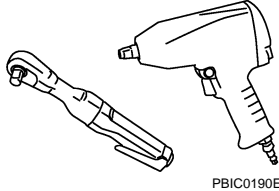
(Kent-Moore No.) Tool name	Description
A: (J-43897-18) B: (J-43897-12) Heated oxygen sensor thread cleaner 	Reconditioning the exhaust system threads before installing a new heated oxygen sensor (Use with anti-seize lubricant shown below.) A: J-43897-18 [18 mm (0.71 in) dia.] for zirconia heated oxygen sensor B: J-43897-12 [12 mm (0.47 in) dia.] for titania heated oxygen sensor C: Mating surface shave cylinder D: Flutes
(—) Anti-seize lubricant (Permatex 133AR or equivalent meeting MIL specification MIL-A-907) 	Lubricating heated oxygen sensor thread cleaner when reconditioning exhaust system threads
(—) Power tool 	Loosening bolts and nuts

F

G

H

I

J

K

L

M

N

O

P

PERIODIC MAINTENANCE

EXHAUST SYSTEM

Inspection

INFOID:000000008141359

Check exhaust pipes, muffler and mounting for improper attachment, leaks, cracks, damage or deterioration.

- If anything is found, repair or replace damaged parts.

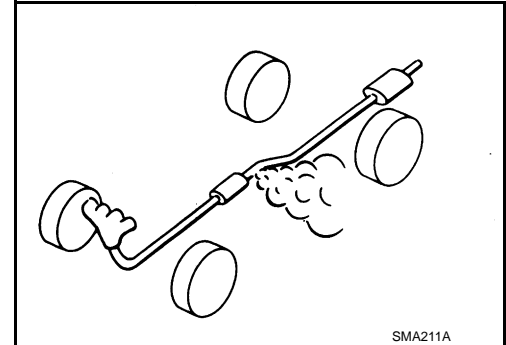

SMA211A

EXHAUST SYSTEM

< REMOVAL AND INSTALLATION >

[VQ35HR]

REMOVAL AND INSTALLATION

EXHAUST SYSTEM

Exploded View

INFOID:000000008141360

A

EX

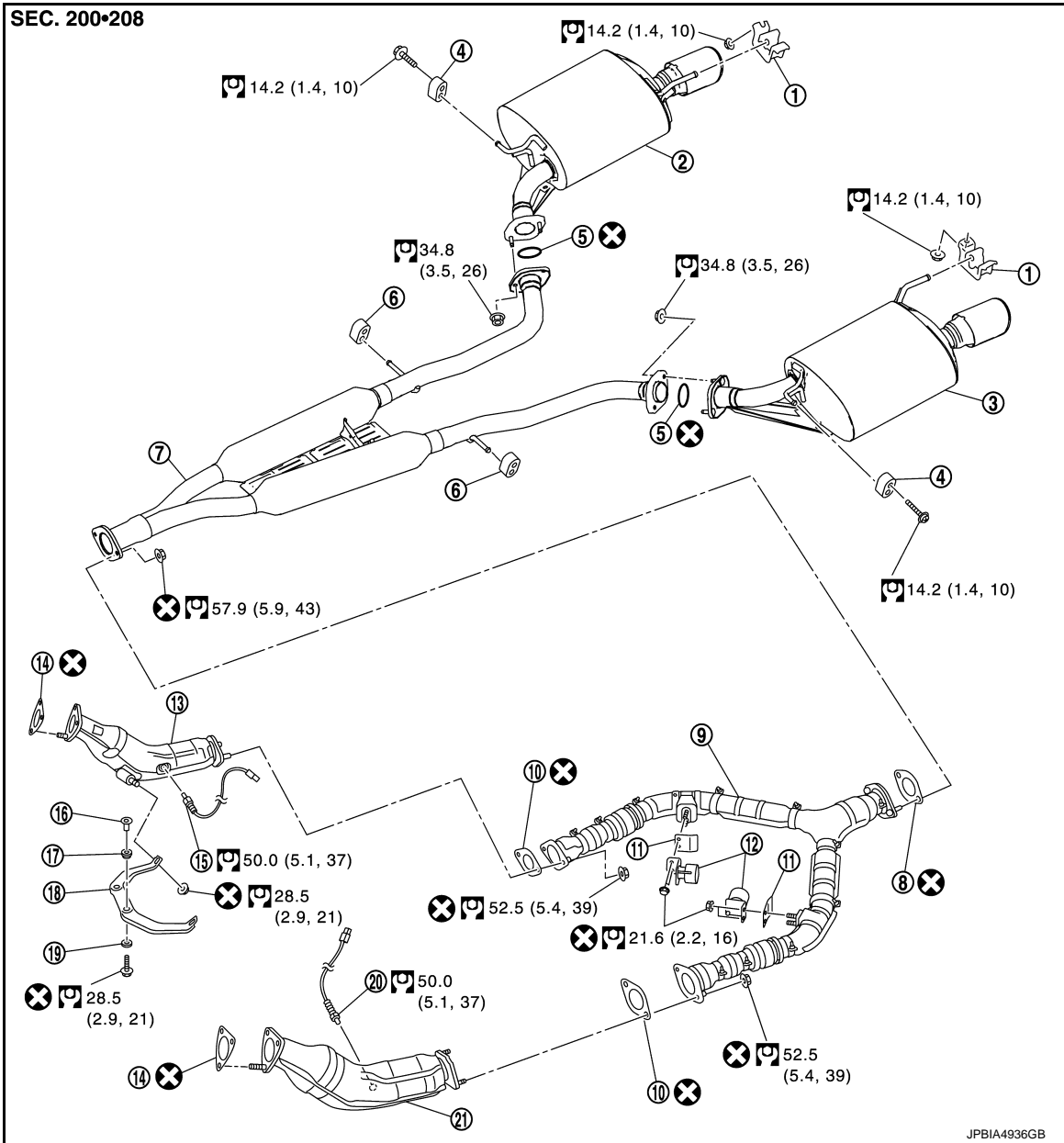

- | | | |
|---------------------------------|-------------------------------------|-------------------------------------|
| 1. Mounting rubber | 2. Main muffler (RH) | 3. Main muffler (LH) |
| 4. Mounting rubber | 5. Ring gasket | 6. Mounting rubber |
| 7. Center muffler | 8. Gasket | 9. Exhaust front tube |
| 10. Gasket | 11. Insulator | 12. Dynamic damper |
| 13. Three way catalyst (bank 1) | 14. Gasket | 15. Heated oxygen sensor 2 (bank 1) |
| 16. Collar | 17. Grommet | 18. Exhaust mounting bracket |
| 19. Grommet | 20. Heated oxygen sensor 2 (bank 2) | 21. Three way catalyst (bank 2) |

: N·m (kg-m, ft-lb)

: Always replace after every disassembly.

C

D

E

F

G

H

I

J

K

L

M

N

O

P

EXHAUST SYSTEM

< REMOVAL AND INSTALLATION >

[VQ35HR]

INFOID:000000008141361

Removal and Installation

REMOVAL

- Disconnect each joint and mounting using power tool.
- Remove heated oxygen sensor 2 as follows:
 - Using heated oxygen sensor wrench [SST: KV10114400 (J-38365)] (C), removal heated oxygen sensor 2.

A : Bank 1

B : Bank 2

↔ : Vehicle front

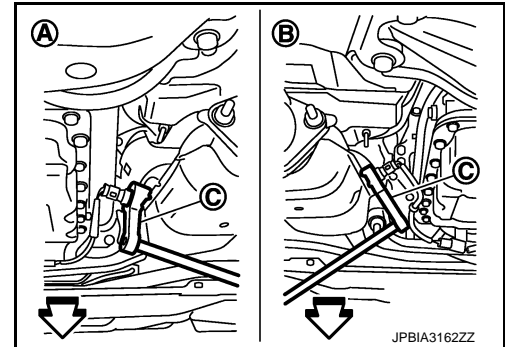

CAUTION:

- Discard any sensor which has been dropped from a height of more than 0.5 m (19.7 in) onto a hard surface such as a concrete floor; use a new one.
- Before installing new sensor, clean exhaust system threads using Oxygen Sensor Thread Cleaner (commercial service tool) and approved Anti-seize Lubricant (commercial service tool)

INSTALLATION

Note the following, and install in the reverse order of removal.

- Check for deformation of the grommets (17 and 19 of Components).
- Insert the collar (16 of Components) vertically.
- Temporarily tighten nuts and bolts when installing exhaust pipe assembly. Tighten them to the specified torque when connecting the vehicle rear to the vehicle front.

CAUTION:

- Always replace exhaust tube gaskets with new ones when reassembling.
- Discard any heated oxygen sensor 2 which has been dropped onto a hard surface such as a concrete floor. Use a new one.
- Before installing a new heated oxygen sensor 2, clean exhaust system threads using the heated oxygen sensor thread cleaner (commercial service tool: J-43897-18 or J-43897-1), and apply the anti-seize lubricant (commercial service tool).
- Never over torque heated oxygen sensor 2. Doing so may cause damage to heated oxygen sensor 2, resulting in the "MIL" coming on.
- Prevent rust preventives from adhering to the sensor body.
- If heat insulator is badly deformed, repair or replace it. If deposits such as mud pile up on the heat insulator, remove them.
- When installing heat insulator avoid large gaps or interference between heat insulator and each exhaust pipe.
- Remove deposits from the sealing surface of each connection. Connect them securely to avoid gases leakage.
- Temporarily tighten mounting nuts on the exhaust manifold side and mounting bolts on the vehicle side. Check each part for unusual interference, and then tighten them to the specified torque.
- When installing each mounting rubber, avoid twisting or unusual extension in up/down and right/left directions.

Inspection

INFOID:000000008141362

INSPECTION AFTER INSTALLATION

- Check clearance between tail tube and rear bumper is even.
- With engine running, check exhaust tube joints for gas leakage and unusual noises.

NOTE:

Perform maintenance mode 5 and maintain the engine speed. Refer to [HBC-89, "Description"](#).

- Check to ensure that mounting brackets and mounting rubbers are installed properly and free from undue stress. Improper installation could result in excessive noise and vibration.